



The Playground of Wireless Dense Networks of the Future

Claudio Cicconetti¹, Arianna Morelli^{1*}, Martin Dräxler², Holger Karl²,
Vincenzo Mancuso³, Vincenzo Sciancalepore³, Rohit Gupta⁴,
Antonio de la Oliva⁵, Isabel Sánchez^{3,5}, Pablo Serrano⁵, Laurent Roullet⁶
¹*Intecs, Italy*, ²*University of Paderborn, Germany*,
³*Institute IMDEA Networks, Spain*, ⁴*Signalion, German*,
⁵*University Carlos III of Madrid, Spain*, ⁶*Alcatel-Lucent Bell Labs, France*,
* presenter e-mail: arianna.morelli@intecs.it

Abstract: This poster presents the key ideas behind the ICT CROWD (Connectivity management for eneRgy Optimised Wireless Dense networks) project, funded by the European Commission. The project moves from the observation that wireless traffic demand is currently growing exponentially. This growing demand can only be satisfied by increasing the density of points of access and combining different wireless technologies. Mobile network operators have already started to push for denser, heterogeneous deployments; however, current technology needs to steer towards efficiency, to avoid unsustainable energy consumption and network performance implosion due to interference. In this context, CROWD pursues four key goals: (i) bringing density-proportional capacity where it is needed, (ii) optimising MAC mechanisms operating in very dense deployments by explicitly accounting for density as a resource rather than as an impediment, (iii) enabling traffic-proportional energy consumption, and (iv) guaranteeing mobile user's quality of experience by designing smarter connectivity management solutions.
<http://www.ict-crowd.eu/>, Twitter @FP7CROWD, Hashtag #FP7CROWD

1. Introduction

Wireless data communication is a constituent part of everyday life for hundreds of millions of people. The number of wireless users is rapidly increasing, the offered load doubling every year, thus yielding a 1000x growth in the next ten years. Additionally, expecting high-quality services and high data rates is becoming normal rather than exceptional. Therefore, considering a density population of 5000 people/Km², which is typical of large European cities like London, Madrid, or Paris, and accounting for 20% of the population being mobile data users, each demanding 1 Mbps, would lead to a demand of 1 Gbps/Km², which can be hardly provided by current wireless infrastructures. The figure grows further if we consider that the per-user demand is expected to increase ten-fold in the next 5 years.¹

The solution to cope with this growing traffic demand necessarily entails using more points of access, by increasing their density (dense network deployments) and/or by using different wireless technologies (heterogeneous deployments).² Following this trend, operators have already started to push for denser deployments,³ building micro-, pico-

¹Cisco Visual Networking Index: Global Mobile Data Traffic Forecast Update, 2010-2015.

²Noticeably, while PHY-layer improvements have produced only a 5x performance improvement over the past decades, and spectrum management has introduced a 25x gain, network capacity has been increased by a factor 1600 by reducing per-cell coverage as explained by Cooper's Law (see Martin Cooper at Arraycomm, <http://www.arraycomm.com/technology/coopers-law>)

³WLAN Scalability Test Report, Joint Universities Computer Centre, ARUBA Networks

and femto-cells, and installing Wi-Fi hotspots in public areas to inject capacity where the data traffic demand is particularly high.

Currently available solutions for optimising the operation of mobile and wireless networks, including recent advances in PHY-layer techniques like interference cancellation, are not sufficient for heterogeneous and dense deployments like the ones existing or under deployment. Indeed, while PHY approaches have been widely investigated to deal with very dense networks, they take a restricted PHY perspective; they do not consider that higher-layer mechanisms are required to globally optimise per-flow performance by orchestrating mechanisms at different layers and subsystems. Furthermore PHY-based optimisations do not scale with network density and cannot be easily extended to the case of heterogeneous wireless technologies. In fact, the complexity required to optimise multiple nodes in real time becomes prohibitively high when nodes use heterogeneous PHYs.

In a nutshell, the CROWD project aims at building high-capacity energy and resource-efficient wireless dense networks. To do so, the project will devise novel mechanisms for connectivity management, energy-efficient operation, scheduling and random access MAC enhancements, and dynamic backhaul optimisation. These mechanisms will be mutually integrated with each other and span across cell boundaries, technology boundaries, and access/backhaul network boundaries, jointly optimising the performance metrics of these subsystems.

2. Key Challenges

We next describe the key challenges that have been identified to realise a truly and effective very dense RAN.

2.1 Density-proportional capacity

In an ideal setting, the capacity increase would be proportional to the increase in the density of points of access. Therefore, a key challenge is to approach this ideal setting as much as possible by providing a capacity increase approximately proportional to the density increase. Uncoordinated neighbour cells cannot simultaneously operate at full capacity due to interference in the limited available radio spectrum. In order to overcome this impairment, we propose to smartly manage interference in the radio spectrum via load-driven network selection and offloading schemes, distributed power control, opportunistic scheduling, and by properly supporting cooperative multipoint techniques (CoMP) in the backhaul.

2.2 Traffic-proportional energy consumption

It is a key challenge to obtain wireless network energy consumption proportional to the volume of handled traffic. The energy consumed by today's network wireless nodes is barely sensitive to the traffic flows over the wireless links. Therefore, in order to save energy, we aim at modulating the long-term activity cycle of each device, in both access and backhaul, based on traffic conditions, i.e., by using smart algorithms to switch on/off base stations and access points. On a short-term operation timescale, we target energy saving through energy-driven opportunistic transmissions, thus using the channel at its best conditions, thereby requiring less transmission power and reducing retransmissions due to channel errors. Considering that wireless devices are commonly utilised at 20-30% of the nominal capacity, traffic-proportional mechanisms are then

expected to reduce the power consumption by up to 70%. This figure can be further improved by optimising the routing for minimal energy consumption in the backhaul.

2.3 Mobile user's QoE

Another key challenge is to obtain a mobility management system that guarantees Quality of Experience to users moving through dense, small cells where connectivity management is particularly challenging for mobile users. We target session continuity with stable QoE of mobile users by means of inter-cell and inter-technology management mechanisms. To this aim, we will consider the exploitation of the 802.21-like handover paradigms, the use of reconfigurable backhails, and the development of DMM solutions.

3. CROWD Architecture

This section presents the initial architecture of the CROWD framework. The main concepts explained in section 2. are articulated in the architecture design shown in Figure 1. The CROWD framework builds on top of the concept of district (in Figure 1 there are two districts: the leftmost part is an LTE district while the rightmost is a WiFi district). A district is geographical area where a dense deployment of a certain technology has been installed. A district is homogeneous and several districts can coexist in a certain geographical area. All optimisations pertinent to a certain technology are performed in a per-technology CROWD Local Controller (CLC in Figure 1). The local controllers are by definition entities able to take fast decisions on short time scales, from tens to hundreds of ms, involving multiple cells/APs of a single technology. For the optimisations involving the backhaul and more than a single technology, CROWD has introduced the concept of CROWD Regional Controller (CRC, in Figure 1). The CRC is in charge of coordinating the optimisations involving more than one district or technology and by definition it works at medium-long time scales, from a few seconds and up, based on aggregated data. The combination of local and regional controllers, integrating long and short time scale operations, is the basis to achieve a variety of optimisation mechanisms, such as power cycling, MAC enhancements, inter-cell coordination and so on. Most of the CROWD features are achieved at the MAC level, although optimisations requiring the mobility of the users and architectural improvements to reduce the footprint of the operator would require the use of Distributed Mobility Management (DMM). DMM is an upcoming technology that promises reduced congestion in operator networks and optimised routes between the UE and the correspondent node, by distributing the mobility management functionality across the nodes at the border of the network. In the architecture proposed we plan to integrate the DMM functionality into the EPC, focusing on how to distribute current functionalities performed by the HeNB.

4. Summary and Conclusion

This poster presents the key challenges posed by extremely dense wireless deployments, such as providing: (i) Density-proportional capacity, (ii) Traffic-proportional energy consumption and (iii) Mobile user's QoE. We also present the initial ideas for the architecture of the CROWD network, which is build on the idea of taking advantage of the cooperation and coordination of heterogeneous small cell technologies.

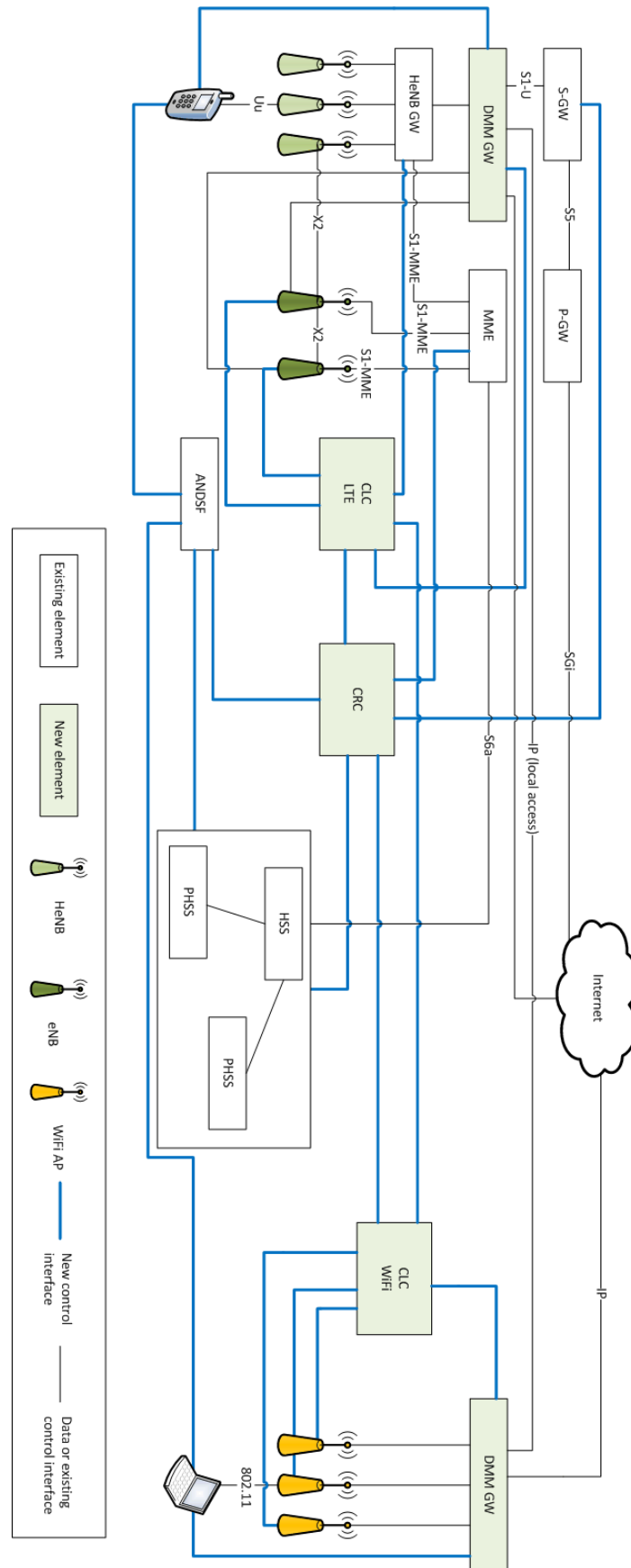

Figure 1: Crowd Architecture